

**** PROPRIETARY DATA ****
 THIS DOCUMENT CONTAINS DATA WHICH IS PROPRIETARY OR CONFIDENTIAL TO WV COMM (WV COMMUNICATIONS INCORPORATED). THIS DOCUMENT AND THE DATA CONTAINED HEREIN SHALL NOT BE USED, DUPLICATED, OR ALTERED WITHOUT THE EXPRESSED WRITTEN CONSENT OF WV COMM. ALL RIGHTS ARE RESERVED.

REVISIONS				
ZONE	REV	DESCRIPTION	DATE	APPROVED
	A	RELEASED	05/30/18	TT
	B	1.22 TALL WAS 1.14	7/24/19	TT

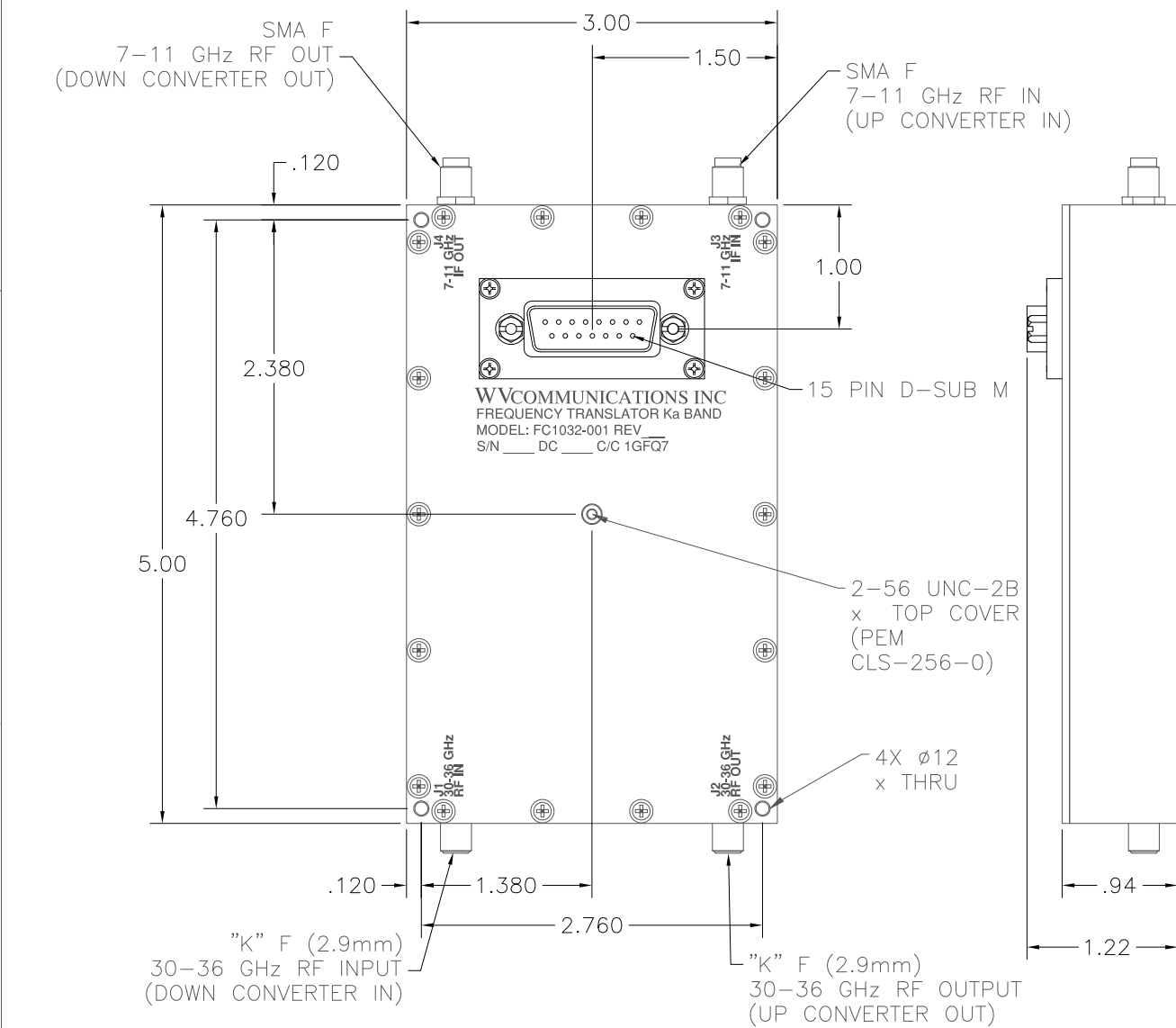

UP Converter Specifications

UP RF FREQUENCY BAND: 30-36GHz
FREQUENCY STEP: 5MHz
RF OUTPUT POWER RANGE: -60 to -10dBm ±2dB Maximum
SPURIOUS LEVEL: -60dBc Maximum
HARMONIC LEVEL: -50dBc in band / -60dBc out of band Maximum
OUTPUT VSWR: 2:1 Maximum (Ref 50Ω)
ISOLATION: -70dBc (IF input to IF output)

Down Converter Specifications

DOWN FREQUENCY BAND: 7-11GHz
FREQUENCY STEP: 5MHz
IF POWER OUTPUT RANGE: -60 to -10dBm ±2dB
SPURIOUS LEVEL: -60dBc Maximum
HARMONIC LEVEL: -50dBc in band / -60dBc out of band Maximum
NOISE FIGURE: 5dB Maximum at +25°C
P1dB COMPRESSION PT: -9dBm Minimum at the IF output port
INPUT VSWR: 2:1 Maximum (Ref 50Ω)
ISOLATION: -70dBc Minimum (RF input to RF output)

Unit Specifications

LO FREQUENCY RANGE: 23-25GHz
LO PHASE NOISE: -70dBc/Hz Maximum @ 100Hz Offset
 -80dBc Maximum @ 1kHz Offset
 -85dBc Maximum @ 10kHz Offset
 -90dBc Maximum @ 100kHz Offset
 -110dBc Maximum @ 1MHz Offset

FREQUENCY STABILITY: Stable within 3 minutes after applying power and to within ±100kHz of the input frequency within ±100kHz in 100uSec Maximum

FREQUENCY SWITCHING TIME
LO LEAKAGE -40dBm Maximum
GAIN VARIATION ±2dB Maximum
SPURIOUS -60dBc Maximum

INPUT/OUTPUT IMPEDANCE 50Ω Nominal
CONTROL: Via Clock/Date/Enable

DC VOLTAGE & CURRENT: 28±3Vdc at 2A Maximum
TEMPERATURE RANGES: Operating -40 to +71°C

PIN ASSIGNMENTS	
PIN #	FUNCTION
1	+28V IN
2	+28V IN
3	GND (CHASSIS & 28V RETURN)
4	GND (CHASSIS & 28V RETURN)
5	GND
6	GND
7	NC
8	NC
9	GND
10	NC
11	NC
12	CLOCK IN
13	DATA IN
14	LATCH ENGAGE IN
15	LOCK DETECT OUT

UNLESS OTHERWISE SPECIFIED: DIMENSIONS ARE IN INCHES. TOLERANCES ARE:
 FRACTIONS DECIMALS ANGLES HOLES
 ± 1/64 .XX±.01 ± 0°30' .XX±.005
 .XXX±.005 .XXX±.003 .XXX-.001
 MACHINED FINISH: 32 RMS REMOVE BURRS .005 MAX

900-50425-001	FC1032-001	FINISH
NEXT ASSEMBLY	USED ON	
APPLICATION	DO NOT SCALE DRAWING	

APPROVALS		DATE
DRAWN	SERGIO V.	05/30/18
CHECKED	TT	05/30/18
MECH ENGR	SV	05/30/18
ELEC ENGR	JT	05/30/18
PRODUCTION	AM	05/30/18
Q.A.	SG	05/30/18

WV Communications 1125-A Business Center Circle
 Newbury Park, CA

OUTLINE DRAWING
FREQUENCY TRANSLATOR
Ka BAND FC1032-001

SIZE	CAGE CODE	DWG. NO.	REV
C	1GFQ7	050-50990-001	B
SCALE	MODEL: FC1032-001	SHEET	1 OF 1

DWG. NO. 050-50990-001 REV. B

DC-FORM-0015-3, REV. C, 06/08