

**** PROPRIETARY DATA ****
 THIS DOCUMENT CONTAINS DATA WHICH IS PROPRIETARY OR CONFIDENTIAL TO WV COMM (WV COMMUNICATIONS INCORPORATED). THIS DOCUMENT AND THE DATA CONTAINED HEREIN SHALL NOT BE USED, DUPLICATED, OR ALTERED WITHOUT THE EXPRESSED WRITTEN CONSENT OF WV COMM. ALL RIGHTS ARE RESERVED.

REVISIONS				
ZONE	REV	DESCRIPTION	DATE	APPROVED
	A	RELEASED	3/17/2009	TT
	B	MOVED FAN AND CONNECTOR LOCATIONS	06/25/10	TT

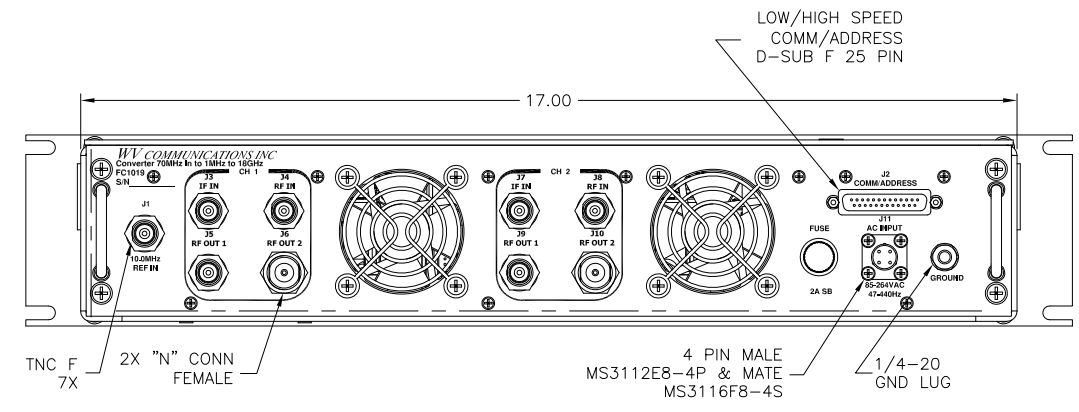

Mar-1-2011

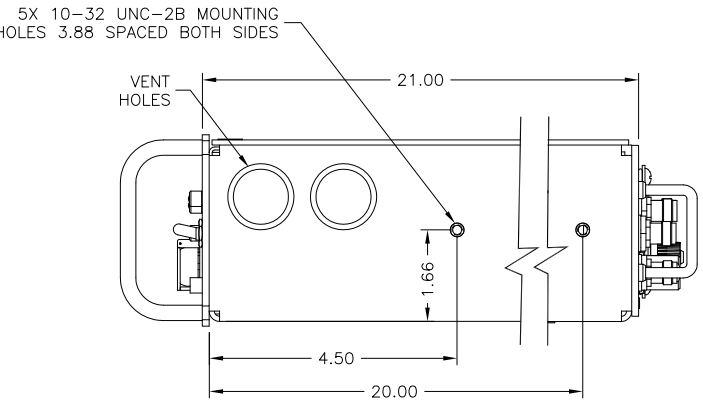
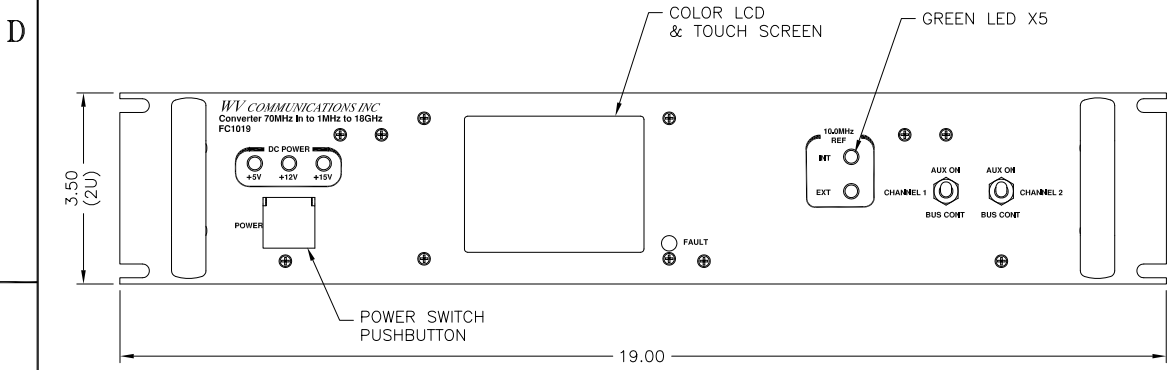
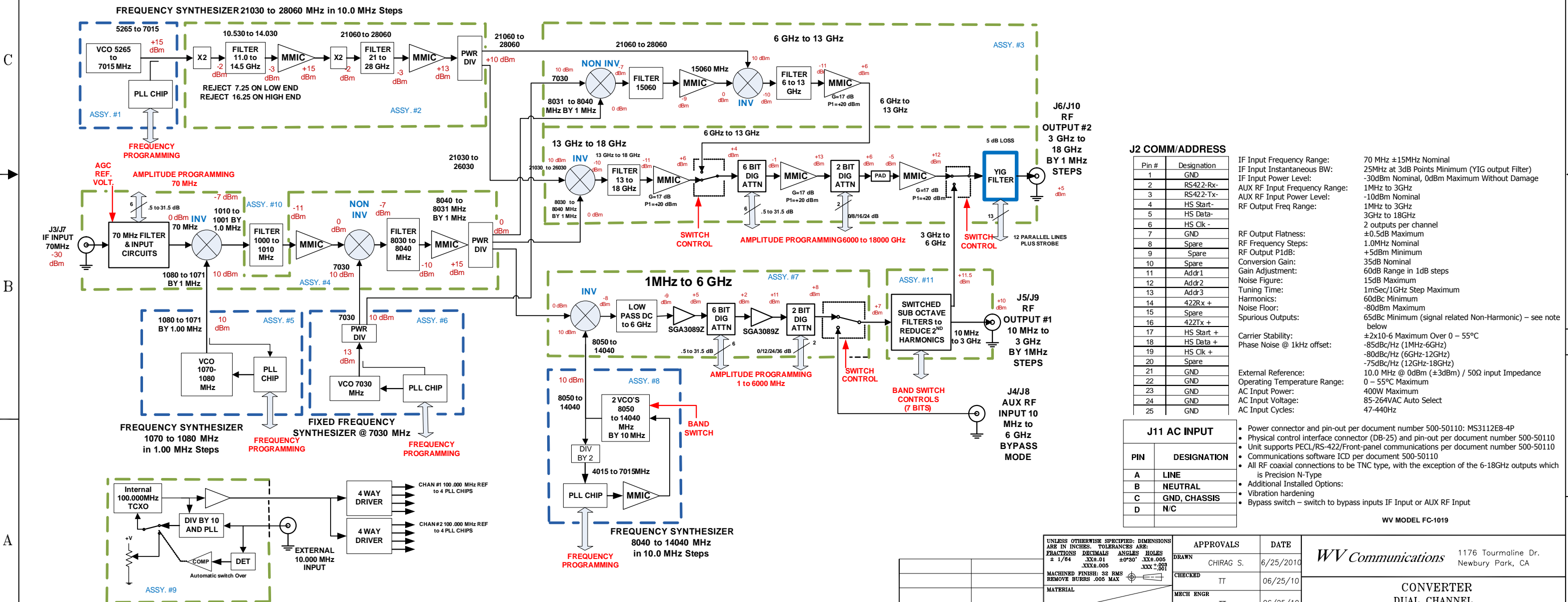

J2 COMM/ADDRESS

Pin #	Designation
1	GND
2	RS422-Rx-
3	RS422-Tx-
4	HS Start-
5	HS Data-
6	HS Clk-
7	GND
8	Spare
9	Spare
10	Spare
11	Addr1
12	Addr2
13	Addr3
14	422Rx+
15	Spare
16	422Tx+
17	HS Start+
18	HS Data+
19	HS Clk+
20	Spare
21	GND
22	GND
23	GND
24	GND
25	GND

IF Input Frequency Range: 70 MHz ±15MHz Nominal
 IF Input Instantaneous BW: 25MHz at 3dB Points Minimum (YIG output Filter)
 IF Input Power Level: -30dBm Nominal, 0dBm Maximum Without Damage
 AUX RF Input Frequency Range: 1MHz to 3GHz
 AUX RF Input Power Level: -10dBm Nominal
 RF Output Freq Range: 1MHz to 3GHz
 3GHz to 18GHz
 2 outputs per channel
 ±0.5dB Maximum
 RF Output Flatness: 1.0MHz Nominal
 RF Frequency Steps: +5dBm Minimum
 Conversion Gain: 35dB Nominal
 Gain Adjustment: 60dB Range in 1dB steps
 Noise Figure: 15dB Maximum
 Tuning Time: 1mSec/1GHz Step Maximum
 Harmonics: 60dBc Minimum
 Noise Floor: -80dBm Maximum
 Spurious Outputs: 65dBc Minimum (signal related Non-Harmonic) – see note below
 Carrier Stability: ±2x10⁻⁶ Maximum Over 0 – 55°C
 Phase Noise @ 1kHz offset: -85dBc/Hz (1MHz-6GHz)
 -80dBc/Hz (6GHz-12GHz)
 -75dBc/Hz (12GHz-18GHz)
 10.0 MHz @ 0dBm (±3dBm) / 50Ω input Impedance
 0 – 55°C Maximum
 External Reference: 400W Maximum
 Operating Temperature Range: 85-264VAC Auto Select
 AC Input Power: 47-440Hz
 AC Input Voltage: 47-440Hz
 AC Input Cycles:

J11 AC INPUT

PIN	DESIGNATION
A	LINE
B	NEUTRAL
C	GND, CHASSIS
D	N/C

• Power connector and pin-out per document number 500-50110: MS3112E8-4P
 • Physical control interface connector (DB-25) and pin-out per document number 500-50110
 • Unit supports PECL/RS-422/Front-panel communications per document number 500-50110
 • Communications software ICD per document 500-50110
 • All RF coaxial connections to be TNC type, with the exception of the 6-18GHz outputs which is Precision N-Type
 • Additional Installed Options:
 • Vibration hardening
 • Bypass switch – switch to bypass inputs IF input or AUX RF Input

WV MODEL FC-1019

NOTE:
 FOR CLARITY – ONLY 1 CHANNEL OF 2 IS SHOWN

UNLESS OTHERWISE SPECIFIED: DIMENSIONS ARE IN INCHES. TOLERANCES ARE:
 FRACTIONS DECIMALS ANGLES HOLES
 ± 1/64 .XXX.01 ±0°30' .XXX+.005
 MACHINED FINISH: 32 RMS REMOVE BURRS .005 MAX
 MATERIAL
 FINISH

APPROVALS	DATE
DRAWN CHIRAG S.	6/25/2010
CHECKED TT	06/25/10
MECH ENGR TT	06/25/10
ELEC ENGR UY	06/25/10
PRODUCTION AM	06/25/10
Q.A. DB	06/25/10

APPROVALS	DATE
DRAWN CHIRAG S.	6/25/2010
CHECKED TT	06/25/10
MECH ENGR TT	06/25/10
ELEC ENGR UY	06/25/10
PRODUCTION AM	06/25/10
Q.A. DB	06/25/10

WV Communications 1176 Tourmaline Dr. Newbury Park, CA

CONVERTER DUAL CHANNEL
 70.0MHz to 1MHz – 18GHz

SIZE	CAGE CODE	DWG. NO.	REV
D	1GFQ7	050-50711	B

SCALE NONE SHEET 1 OF 1